

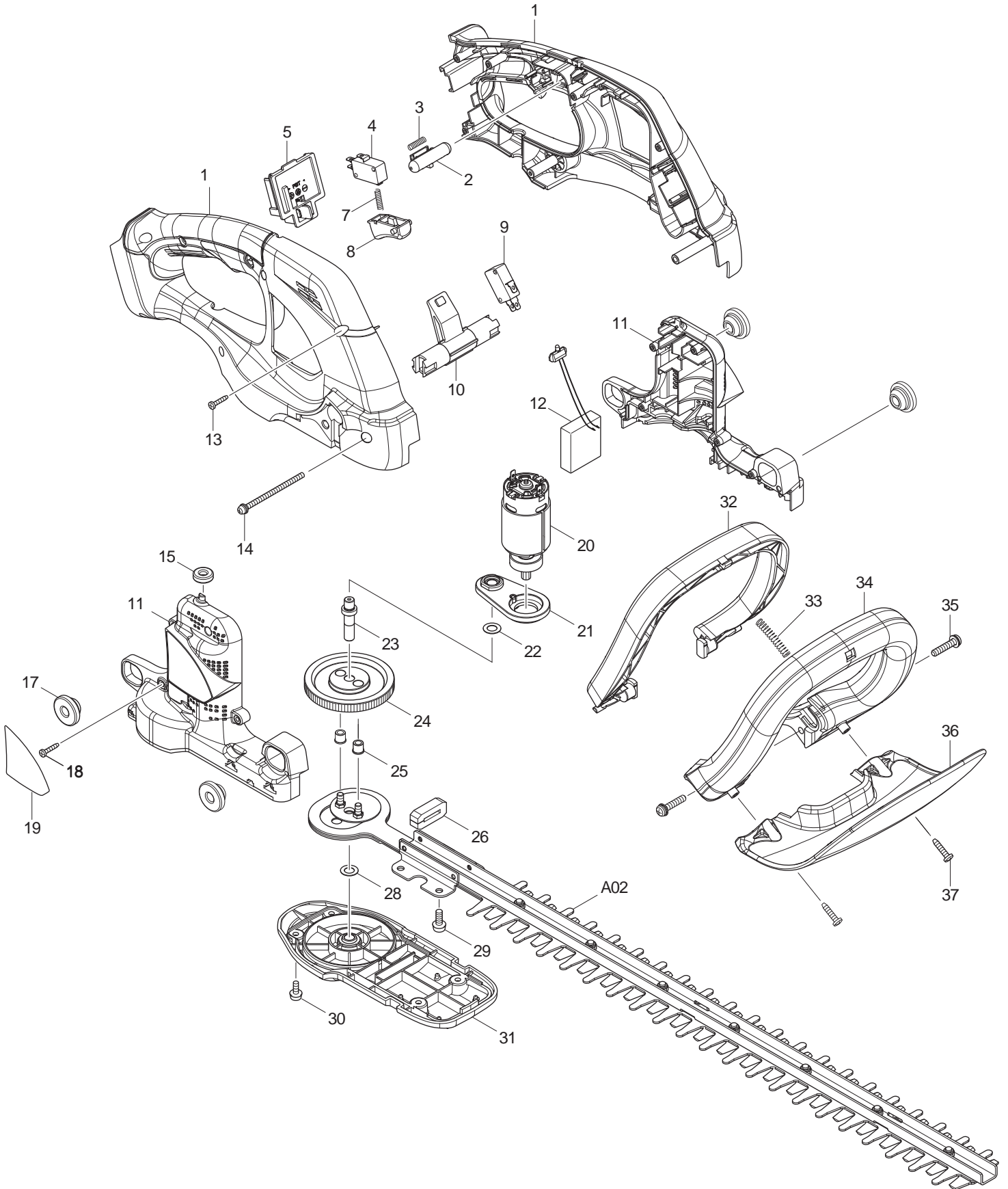

04 - 2014  
DUH523Z / DUH523SF  
18V 22" HEDGE TRIMMER



Item No.	Type	Sub	Part No.	Description	Qty	Unit
001			187286-4	HANDLE SET	1	SET
002			452438-9	LOCK OFF BUTTON	1	PC.
003			231473-8	COMPRESSION SPRING 4	1	PC.
004			651852-8	SWITCH V-15-1A5	1	PC.
005			643852-2	TERMINAL	1	PC.
007			231473-8	COMPRESSION SPRING 4	1	PC.
008			417564-1	SWITCH LEVER	1	PC.
009			651852-8	SWITCH V-15-1A5	1	PC.
010			452681-0	SWITCH ARM	1	PC.
011			187285-6	MOTOR HOUSING SET	1	SET
012			632A82-6	CONTROLLER UNIT	1	PC.
013			266429-2	TAPPING SCREW 3X16	6	PC.
014			911193-7	PAN HEAD SCREW M4X65	1	PC.
015			424195-9	RUBBER RING 6	1	PC.
017			424394-3	RUBBER RING 8	4	PC.
018			266429-2	TAPPING SCREW 3X16	5	PC.
019			815U45-9	NAME PLATE F/DUH523	1	PC.
020			629930-2	DC MOTOR	1	PC.
021			141211-9	BEARING BOX COMPLETE	1	PC.
022			253215-0	FLAT WASHER 8	1	PC.
023			326034-8	SPINDLE	1	PC.
024			227281-3	SPUR GEAR 93	1	PC.
025			262570-9	NYLON SLEEVE 5	2	PC.
026			423417-4	DUST GUARD	1	PC.
028			253215-0	FLAT WASHER 8	1	PC.
029			911218-7	PAN HEAD SCREW M5X14	4	PC.
030			911113-1	PAN HEAD SCREW M4X10	4	PC.
031			453317-4	UNDER COVER	1	PC.
032			452678-9	SWITCH LEVER B	1	PC.
033			234261-2	COMPLESSION SPRING 5	1	PC.
034			452682-8	FRONT GRIP	1	PC.
035			911243-8	PAN HEAD SCREW M5X25	2	PC.
036			142733-2	PROTECTOR COMPLETE	1	PC.
		INC.	804F56-9	CAUTION LABEL (W/NO BATTERY NO.)	1	PC.
		INC.	804F57-7	CAUTION LABEL (W/NO BATTERY NO.)	1	PC.
037			265995-6	TAPPING SCREW 4X18	2	PC.
C01			820V26-6	CARTON F/DUH523Z	1	PC.

### **ACCESSORIES**

**- Visit [www.makita.ca](http://www.makita.ca) for more accessories information -**

A01	1		453723-3	* BLADE COVER	1	PC.
A01	2		452685-2	* BLADE COVER	1	PC.
A02	1		195846-8	* SHEAR BLADE COMPLETE SET	1	PC.
		INC.	188605-7	* OIL VESSEL SET	1	PC.
		INC.	262570-9	* NYLON SLEEVE 5	2	PC.
A02	2		195769-0	* SHEAR BLADE COMPLETE SET	1	PC.
		INC.	188605-7	* OIL VESSEL SET	1	PC.
		INC.	262570-9	* NYLON SLEEVE 5	2	PC.
A03			195050-9	CHIP RECEIVER ASSEMBLY SET	1	PC.
A04			-----	18V LI-ION BATTERY		
A05			-----	BATTERY CHARGER		
A06			450128-8	LI-ION BATTERY ACCESSORIES	1	PC.

**SERVICE CHANGES**

**1. Changes on Shear blade and Blade cover** (T/I#D8629)

<b>Item No.</b>	<b>Description</b>	<b>Type 1</b>	<b>Type 2</b>
A01	BLADE COVER	453723-3	452685-2
A02	SHEAR BLADE SET	195846-8	195769-0

Above parts are completely interchangeable as a set.